

MAGNETIC LEVEL SWITCH

for ASPHALT or BITUMEN ITHLA-x/B

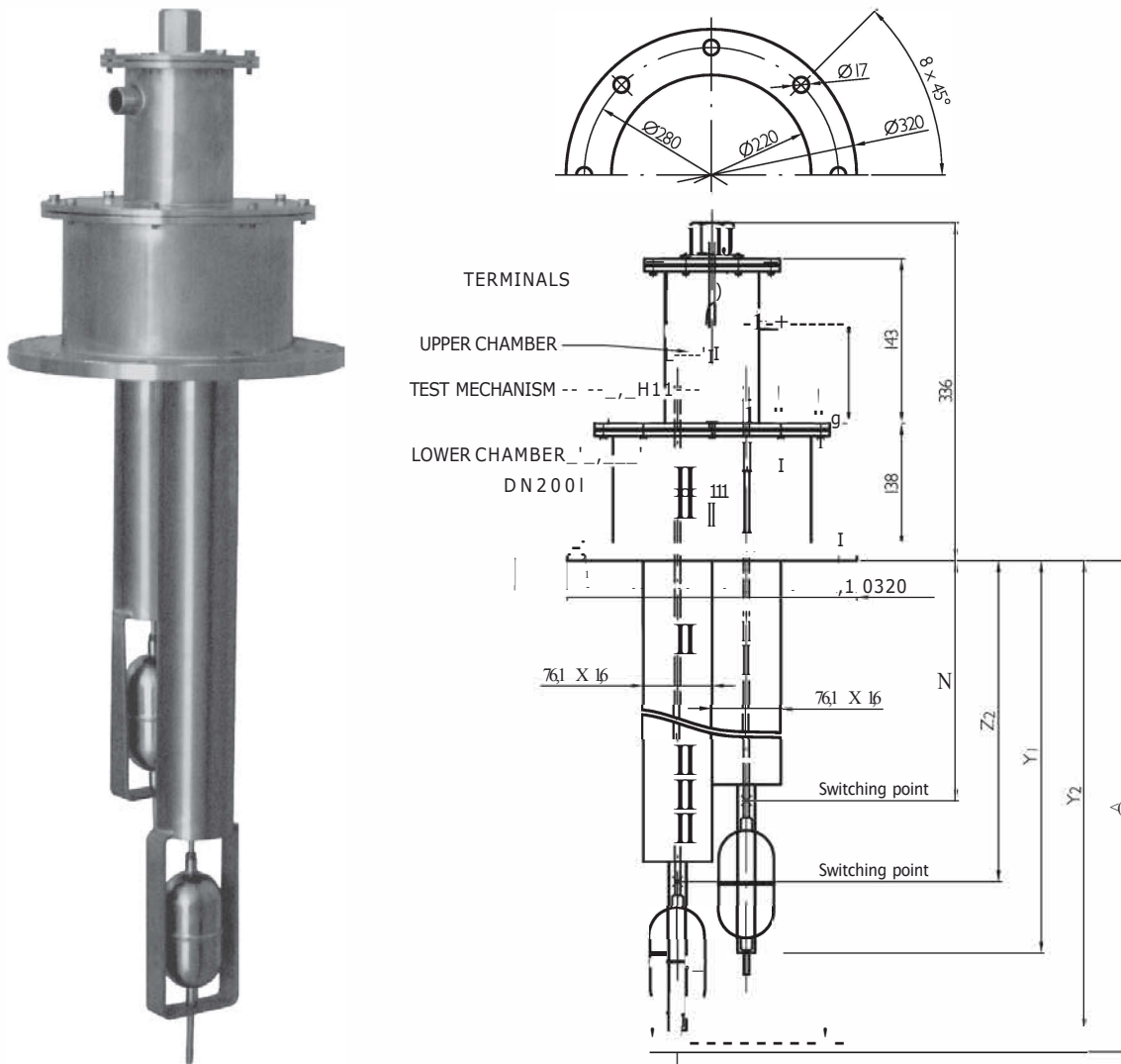

TECHNICAL CHARACTERISTICS

- Type ITHLA-2/B (double point)
- Type ITHLA-1/B (single point)
- AISI 316L stainless steel construction
- When high level or overflow alarm is required, single point magnetic level switch ITHLA-1/B is used. When both (high level and overflow) alarms are required, double point magnetic level switch ITHLA-2/B should be used.
- Can be installed in dangerous area and connected via intrinsically safe isolator situated in non-hazardous area. (According to explosion protection standards, the equipment is regarded as a "simple apparatus" due to the fact that it contains only passive elements such as reed switch and resistors.)
- Operating temperature: up to 280 °C
- Connection head protection: IP56